

Corporate and Business Law (MLA) (F4) December 2014 to June 2015

This syllabus and study guide is designed to help with planning study and to provide detailed information on what could be assessed in any examination session.

THE STRUCTURE OF THE SYLLABUS AND STUDY GUIDE

Relational diagram of paper with other papers

This diagram shows direct and indirect links between this paper and other papers preceding or following it. Some papers are directly underpinned by other papers such as Advanced Performance Management by Performance Management. These links are shown as solid line arrows. Other papers only have indirect relationships with each other such as links existing between the accounting and auditing papers. The links between these are shown as dotted line arrows. This diagram indicates where you are expected to have underpinning knowledge and where it would be useful to review previous learning before undertaking study.

Overall aim of the syllabus

This explains briefly the overall objective of the paper and indicates in the broadest sense the capabilities to be developed within the paper.

Main capabilities

This paper's aim is broken down into several main capabilities which divide the syllabus and study guide into discrete sections.

Relational diagram of the main capabilities

This diagram illustrates the flows and links between the main capabilities (sections) of the syllabus and should be used as an aid to planning teaching and learning in a structured way.

Syllabus rationale

This is a narrative explaining how the syllabus is structured and how the main capabilities are linked. The rationale also explains in further detail what the examination intends to assess and why.

Detailed syllabus

This shows the breakdown of the main capabilities (sections) of the syllabus into subject areas. This is the blueprint for the detailed study guide.

Approach to examining the syllabus

This section briefly explains the structure of the examination and how it is assessed.

Study Guide

This is the main document that students, tuition providers and publishers should use as the basis of their studies, instruction and materials. Examinations will be based on the detail of the study guide which comprehensively identifies what could be assessed in any examination session. The study guide is a precise reflection and breakdown of the syllabus. It is divided into sections based on the main capabilities identified in the syllabus. These sections are divided into subject areas which relate to the sub-capabilities included in the detailed syllabus. Subject areas are broken down into sub-headings which describe the detailed outcomes that could be assessed in examinations. These outcomes are described using verbs indicating what exams may require students to demonstrate, and the broad intellectual level at which these may need to be demonstrated (*see intellectual levels below).

INTELLECTUAL LEVELS

The syllabus is designed to progressively broaden and deepen the knowledge, skills and professional values demonstrated by the student on their way through the qualification.

The specific capabilities within the detailed syllabuses and study guides are assessed at one of three intellectual or cognitive levels:

Level 1: Knowledge and comprehension
Level 2: Application and analysis
Level 3: Synthesis and evaluation

Very broadly, these intellectual levels relate to the three cognitive levels at which the Knowledge module, the Skills module and the Professional level are assessed.

Each subject area in the detailed study guide included in this document is given a 1, 2, or 3 superscript, denoting intellectual level, marked at the end of each relevant line. This gives an indication of the intellectual depth at which an area could be assessed within the examination. However, while level 1 broadly equates with the Knowledge module, level 2 equates to the Skills module and level 3 to the Professional level, some lower level skills can continue to be assessed as the student progresses through each module and level. This reflects that at each stage of study there will be a requirement to broaden, as well as deepen capabilities. It is also possible that occasionally some higher level capabilities may be assessed at lower levels.

LEARNING HOURS AND EDUCATION RECOGNITION

The ACCA qualification does not prescribe or recommend any particular number of learning hours for examinations because study and learning patterns and styles vary greatly between people and organisations. This also recognises the wide diversity of personal, professional and educational circumstances in which ACCA students find themselves.

As a member of the International Federation of Accountants, ACCA seeks to enhance the education recognition of its qualification on both national and international education frameworks, and with educational authorities and partners globally. In doing so, ACCA aims to ensure that its qualifications are recognized and valued by governments, regulatory authorities and employers across all sectors. To this end, ACCA qualifications are currently recognized on the education frameworks in several countries. Please refer to your national education framework regulator for further information.

Each syllabus contains between 23 and 35 main subject area headings depending on the nature of the subject and how these areas have been broken down.

GUIDE TO EXAM STRUCTURE

The structure of examinations varies within and between modules and levels.

The Fundamentals level examinations contain 100% compulsory questions to encourage candidates to study across the breadth of each syllabus.

The Knowledge module is assessed by equivalent two-hour paper based and computer based examinations.

The Skills module examinations F5-F9 are all paper based three-hour papers containing a mix of objective and longer type questions. The *Corporate and Business Law* (F4) paper is a two-hour paper based examination from the December 2014 examination session.

The Professional level papers are all three-hour paper based examinations, all containing two sections. Section A is compulsory, but there will be some choice offered in Section B.

For all three hour examination papers, ACCA has introduced 15 minutes reading and planning time.

This additional time is allowed at the beginning of each three-hour examination to allow candidates to read the questions and to begin planning their answers before they start writing in their answer books. This time should be used to ensure that all the information and exam requirements are properly read and understood.

During reading and planning time candidates may only annotate their question paper. They may not write anything in their answer booklets until told to do so by the invigilator.

The Essentials module papers all have a Section A containing a major case study question with all requirements totalling 50 marks relating to this case. Section B gives students a choice of two from three 25 mark questions.

Section A of both the P4 and P5 Options papers contain one 50 mark compulsory question, and Section B will offer a choice of two from three questions each worth 25 marks each.

Section A of each of the P6 and P7 Options papers contains 60 compulsory marks from two questions; question 1 attracting 35 marks, and question 2 attracting 25 marks. Section B of both these Options papers will offer a choice of two from three questions, with each question attracting 20 marks.

All Professional level exams contain four professional marks.

The pass mark for all ACCA Qualification examination papers is 50%.

ACCA reserves the right to examine anything contained within the study guide at any examination session. This includes knowledge, techniques, principles, theories, and concepts as specified.

For the financial accounting, audit and assurance, law and tax papers except where indicated otherwise, ACCA will publish *examinable documents* once a year to indicate exactly what regulations and legislation could potentially be assessed within identified examination sessions..

For paper based examinations regulation *issued* or legislation *passed* on or before 31st August annually, will be examinable from 1st September of the following year to 31st August of the year after that. Please refer to the examinable documents for the paper (where relevant) for further information.

Regulation issued or legislation passed in accordance with the above dates may be examinable even if the *effective* date is in the future.

The term issued or passed relates to when regulation or legislation has been formally approved.

The term effective relates to when regulation or legislation must be applied to an entity transactions and business practices.

The study guide offers more detailed guidance on the depth and level at which the examinable documents will be examined. The study guide should therefore be read in conjunction with the examinable documents list.

Syllabus

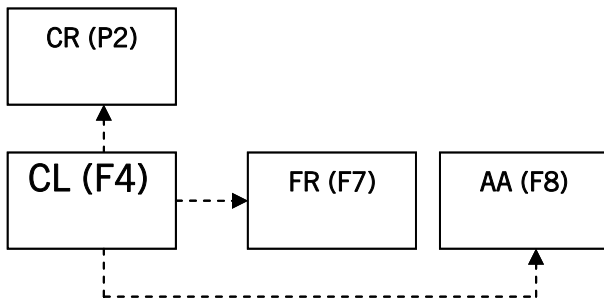

AIM

To develop knowledge and skills in the understanding of the general legal framework, and of specific legal areas relating to business, recognising the need to seek further specialist legal advice where necessary.

MAIN CAPABILITIES

On successful completion of this paper candidates should be able to:

- A** Identify the essential elements of the legal system including the main sources of law
- B** Recognise and apply the appropriate legal rules relating to the law of obligations
- C** Explain and apply the law relating to employment relationships
- D** Distinguish between alternative forms and constitutions of business organisations
- E** Recognise and compare types of capital and the financing of companies
- F** Describe and explain how companies are managed, administered and regulated
- G** Recognise the legal implications relating to insolvency law
- H** Demonstrate an understanding of corporate fraudulent and criminal behaviour

RELATIONAL DIAGRAM OF MAIN SYLLABUS CAPBILITIES

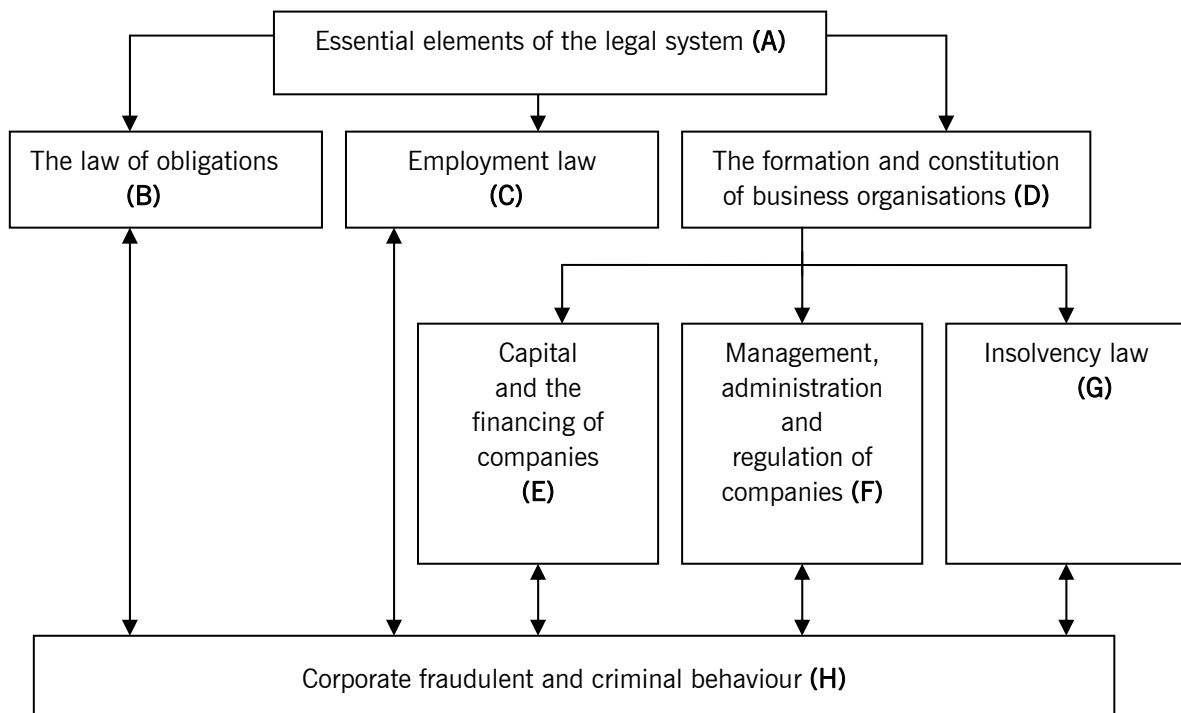

RATIONALE

Corporate and Business Law is essentially divided into eight areas.

The syllabus starts with an introduction to the overall legal system of Malta such as the court system and sources of law, including human rights legislation. It then leads into the area of the law of obligations including contracts and tort, which underpin business transactions generally.

The syllabus then covers a range of specific legal areas relating to various aspects of business of most concern to finance professionals. These are the law relating to employment and the law relating to companies.

These laws include the formation and constitution of companies, the financing of companies and types of capital, and the day to day management, the administration and regulation of companies and legal aspects of insolvency law.

The final section links back to all the previous areas. This section deals with corporate fraudulent and criminal behaviour.

DETAILED SYLLABUS

A Essential elements of the legal system

1. Court structure
2. Sources of law
3. Human rights

B The law of obligations

1. Formation of contract
2. Breach of contract and remedies
3. The law of torts
4. Professional negligence

C Employment law

1. Contract of employment

2. Dismissal and redundancy

D The formation and constitution of business organisations

1. Agency law
2. Partnerships
3. Corporations and legal personality
4. The formation and constitution of a company

E Capital and the financing of companies

1. Share capital
2. Loan capital
3. Capital maintenance and dividend law

F Management, administration and regulation of companies

1. Company directors
2. Other company officers
3. Company meetings and resolutions

G Insolvency law

1. Insolvency and corporate recovery

H Corporate fraudulent and criminal behaviour

1. Fraudulent and criminal behaviour

APPROACH TO EXAMINING THE SYLLABUS

The syllabus is assessed by a two-hour paper-based examination.

The examination consists of:

Section A

- 25 x 2 mark objective test questions 50%
- 20 x 1 mark objective test questions 20%
-

Section B

- 5 x 6 mark multi-task questions 30%
- 100%.

All questions are compulsory.

NOTE ON CASE LAW

Candidates should support their answers with analysis referring to cases or examples. There is no need to detail the facts of the case. Remember, it is the point of law that the case establishes that is important, although knowing the facts of cases can be helpful as sometimes questions include scenarios based on well-known cases. Further it is not necessary to quote section numbers of Acts.

Study Guide

A ESSENTIAL ELEMENTS OF THE LEGAL SYSTEM

1. Court structure

- a) Define law and distinguish types of law.^[1]
- b) Explain the structure and jurisdiction of the courts.^[1]

2. Sources of law

- a) Explain what is meant by case law and precedent within the context of the hierarchy of the courts.^[1]
- b) Explain legislation and evaluate delegated legislation.^[1]
- c) Illustrate the rules and presumptions used by the courts in interpreting statutes.^[1]

3. Human rights

- a) Identify the concept of human rights as expressed in the Constitution of Malta and legislation.^[2]
- b) Explain the impact of human rights law on statutory interpretation.^[2]
- c) Explain the impact of human rights law on local legislation.^[2]

B THE LAW OF OBLIGATIONS

1. Formation of contract

- a) Distinguish between and analyse the internal and external requisites for a valid contract.^[2]
- b) Analyse the differences between internal and external requisites.^[2]
- c) Explain the meaning of an offer and distinguish it from an invitation to treat.^[2]
- d) Explain the termination of an offer.^[2]
- e) Explain the meaning and consequence of acceptance.^[2]

- f) Analyse the doctrine of privity.^[2]

2. Breach of contract and remedies

- a) Explain the meaning and effect of breach of contract.^[2]
- b) Explain the rules relating to the award of damages.^[2]

3. The law of torts

- a) Explain the meaning of tort and quasi-tort.^[2]
- b) Explain the meaning of contract and quasi-contracts.^[2]
- c) Identify examples of torts and quasi-torts.^[2]
- d) Identify examples of quasi-contracts.^[2]
- e) Distinguish between quasi-contracts and quasi-torts.^[2]

4. Professional negligence

- a) Explain and analyse the duty of care of accountants and auditors, including the concept of professional negligence.^[2]

C EMPLOYMENT LAW

1. Contract of employment

- a) Distinguish between employees and the self-employed.^[1]
- b) Distinguish between full-time and part-time employment.^[1]
- c) Explain the nature of the contract of employment and the main duties placed on the parties on the employer and employee.^[1]
- d) Explain the terms of a contract of employment and the information to be given to employees in the absence of a contract.^[2]
- e) Explain the concept of probation.^[2]

- f) Explain the protection afforded to employees to ensure due receipt of wages.^[2]

2. Dismissal and redundancy

- a) Distinguish between definite and indefinite term contracts of employment.^[2]
- b) Distinguish between termination of definite and indefinite term contracts of employment.^[2]
- c) Explain termination on grounds of redundancy.^[2]
- d) Explain what is meant by redundancy and termination for a good and sufficient cause.^[2]
- e) Discuss the remedies available to those who have been subject to unfair dismissal or redundancy.^[2]

D THE FORMATION AND CONSTITUTION OF BUSINESS ORGANISATIONS

1. Agency law

- a) Define the role of the agent and give examples of such relationships in particular a mandate relationship.^[2]
- b) Explain the formation of an agency relationship.^[2]
- c) Define the rights of the parties to an agency relationship.^[2]
- d) Explain the potential liability of both principal and agent.^[2]

2. Partnerships

- a) Demonstrate the nature of the different types of commercial partnerships.^[2]
- b) Discuss the formation of a partnership, including the contents of partnership deeds and the procedure to make changes thereto.^[2]
- c) Explain the rights and duties of partners in relation to partnership activity and its management.^[2]

- d) Analyse the liability of various partners for partnership debts.^[2]

- e) Explain the dissolution of a partnership, and partners' subsequent rights and liabilities.^[2]

3. Corporations and legal personality

- a) Distinguish between sole traders, commercial partnerships and companies.^[1]
- b) Explain the meaning and effect of limited liability.^[2]
- c) Analyse different types of companies, especially private and public companies, including single member private companies and private exempt companies, and the procedure to change the status of a company.^[2]
- d) Illustrate the effect of separate legal personality and the corporate veil.^[2]
- e) Recognise instances where separate personality will be ignored and the corporate veil be lifted.^[2]

4. The formation and constitution of a company

- a) Explain the role and duties of company promoters.^[2]
- b) Describe the procedure for registering companies, both public and private, and the role of the Registrar.^[2]
- c) Describe the statutory books, records and returns that companies must keep or make.^[1]
- d) Explain the content and effect of the memorandum of association.^[2]
- e) Describe the contents of the model articles of association.^[1]
- f) Analyse the procedure to effect changes to the company's constitutional documents.^[2]

E CAPITAL AND THE FINANCING OF COMPANIES

1. Share capital

- a) Examine the different types of share capital.^[1]
- b) Illustrate the different classes of shares and the rights of the holders thereof, and the procedure for altering class rights.^[2]
- c) Explain the procedure for altering capital, including increases in capital for a non-cash consideration.^[2]
- d) Explain the effect of issuing shares at either a discount, or at a premium.^[1]

2. Loan capital

- a) Define companies' borrowing powers.^[1]
- b) Explain the meaning of debentures.^[2]
- c) Distinguish between loan capital and share capital, and the different rights held by shareholders and debentureholders.^[2]
- d) Describe procedure and effect of pledging shares in a company.^[2]

3. Capital maintenance and dividend law

- a) Explain the doctrine of capital maintenance and capital reduction, including a serious loss of capital.^[2]
- b) Explain the rules governing the distribution of dividends in both private and public companies.^[2]

F MANAGEMENT, ADMINISTRATION AND THE REGULATION OF COMPANIES

1. Company directors

- a) Explain the role of directors in the operation of a company, and different types of directors, such as executive/non-executive and shadow directors.^[2]

- b) Discuss the ways in which directors are appointed, can lose their office or be subject to a disqualification order.^[2]

- c) Distinguish between the powers of the board of directors, the managing director/chief executive and individual directors to bind their company.^[2]

- d) Explain the duties that directors owe to their companies.^[2]

2. Other company officers

- a) Discuss the appointment procedure relating to, and the duties and powers of, a company secretary.^[2]

- b) Discuss the appointment procedure relating to, and the duties and rights of a company auditor, and their subsequent removal or resignation.^[2]

3. Company meetings and resolutions

- a) Distinguish between types of meetings: ordinary general meetings and annual general meetings.^[1]

- b) Distinguish between types of resolutions: ordinary and extra-ordinary.^[1]

- c) Explain the procedure for calling and conducting company meetings.^[1]

G INSOLVENCY LAW

1. Insolvency and corporate recovery

- a) Explain the meaning of and procedure involved in voluntary liquidation, including members' and creditors' voluntary liquidation.^[2]

- b) Explain the meaning of and procedure involved in compulsory liquidation.^[2]

- c) Explain the role of the liquidator and the exercise of his powers in both voluntary and compulsory winding up procedures.^[2]

- d) Explain administration as an alternative to winding up.^[2]

- e) Explain the corporate recovery procedure.^[2]
- f) Identify the role of the courts and the special controller in a corporate recovery.^[1]

H CORPORATE FRAUDULENT AND CRIMINAL BEHAVIOUR

1. Fraudulent and criminal behaviour

- a) Recognise the nature and legal control over market abuse.^[2]
- b) Recognise the nature and legal control over money laundering.^[2]
- c) Recognise the nature and legal control over bribery.^[2]
- d) Discuss potential criminal activity in the operation, management and winding up of companies.^[2]
- e) Recognise the nature and control over fraudulent and wrongful trading.^[2]

SUMMARY OF CHANGES TO F4 (MLA)

ACCA periodically reviews its qualification syllabuses so that they fully meet the needs of stakeholders such as employers, students, regulatory and advisory bodies and learning providers.

The main areas that have been deleted from the syllabus are shown in Table 1 below (there have been no additions to the syllabus):

Table 1 – Deletions to F4 (MLA)

| Section and subject area | Syllabus content |
|---------------------------------|--|
| A1b) Court structure | The structure and operation of the tribunals systems |
| H1a) Corporate governance | The idea of corporate governance |
| H1b) Corporate governance | The extra legal codes of corporate governance |
| H1c) Corporate governance | The legal regulation of corporate governance |