

# Corporate and Business Law (SGP) (F4) December 2009

This syllabus and study guide is designed to help with planning study and to provide detailed information on what could be assessed in any examination session.

## THE STRUCTURE OF THE SYLLABUS AND STUDY GUIDE

### Relational diagram of paper with other papers

This diagram shows direct and indirect links between this paper and other papers preceding or following it. Some papers are directly underpinned by other papers such as Advanced Performance Management by Performance Management. These links are shown as solid line arrows. Other papers only have indirect relationships with each other such as links existing between the accounting and auditing papers. The links between these are shown as dotted line arrows. This diagram indicates where you are expected to have underpinning knowledge and where it would be useful to review previous learning before undertaking study.

### Overall aim of the syllabus

This explains briefly the overall objective of the paper and indicates in the broadest sense the capabilities to be developed within the paper.

### Main capabilities

This paper's aim is broken down into several main capabilities which divide the syllabus and study guide into discrete sections.

### Relational diagram of the main capabilities

This diagram illustrates the flows and links between the main capabilities (sections) of the syllabus and should be used as an aid to planning teaching and learning in a structured way.

### Syllabus rationale

This is a narrative explaining how the syllabus is structured and how the main capabilities are linked. The rationale also explains in further detail what the examination intends to assess and why.

### Detailed syllabus

This shows the breakdown of the main capabilities (sections) of the syllabus into subject areas. This is the blueprint for the detailed study guide.

### Approach to examining the syllabus

This section briefly explains the structure of the examination and how it is assessed.

### Study Guide

This is the main document that students, tuition providers and publishers should use as the basis of their studies, instruction and materials. Examinations will be based on the detail of the study guide which comprehensively identifies what could be assessed in any examination session. The study guide is a precise reflection and breakdown of the syllabus. It is divided into sections based on the main capabilities identified in the syllabus. These sections are divided into subject areas which relate to the sub-capabilities included in the detailed syllabus. Subject areas are broken down into sub-headings which describe the detailed outcomes that could be assessed in examinations. These outcomes are described using verbs indicating what exams may require students to demonstrate, and the broad intellectual level at which these may need to be demonstrated (\*see intellectual levels below).

### Reading lists

ACCA examiners will recommend study texts and text books where these are available, which students may read as part of their preparation for the exam. Relevant articles will also be published in *student accountant*.

## INTELLECTUAL LEVELS

The syllabus is designed to progressively broaden and deepen the knowledge, skills and professional values demonstrated by the student on their way through the qualification.

The specific capabilities within the detailed syllabuses and study guides are assessed at one of three intellectual or cognitive levels:

Level 1: Knowledge and comprehension

Level 2: Application and analysis

Level 3: Synthesis and evaluation

Very broadly, these intellectual levels relate to the three cognitive levels at which the Knowledge module, the Skills module and the Professional level are assessed.

Each subject area in the detailed study guide included in this document is given a 1, 2, or 3 superscript, denoting intellectual level, marked at the end of each relevant line. This gives an indication of the intellectual depth at which an area could be assessed within the examination. However, while level 1 broadly equates with the Knowledge module, level 2 equates to the Skills module and level 3 to the Professional level, some lower level skills can continue to be assessed as the student progresses through each module and level. This reflects that at each stage of study there will be a requirement to broaden, as well as deepen capabilities. It is also possible that occasionally some higher level capabilities may be assessed at lower levels.

## LEARNING HOURS

The ACCA qualification does not prescribe or recommend any particular number of learning hours for examinations because study and learning patterns and styles vary greatly between people and organisations. This also recognises the wide diversity of personal, professional and educational circumstances in which ACCA students find themselves.

Each syllabus contains between 23 and 35 main subject area headings depending on the nature of the subject and how these areas have been broken down.

## GUIDE TO EXAM STRUCTURE

The structure of examinations varies within and between modules and levels.

The Fundamentals level examinations contain 100% compulsory questions to encourage candidates to study across the breadth of each syllabus.

The Knowledge module is assessed by equivalent two-hour paper based and computer based examinations.

The Skills module examinations are all paper based three-hour papers. The structure of papers varies from ten questions in the *Corporate and Business Law* (F4) paper to four 25 mark questions in *Financial Management* (F9). Individual questions within all Skills module papers will attract between 10 and 30 marks.

The Professional level papers are all three-hour paper based examinations, all containing two sections. Section A is compulsory, but there will be some choice offered in Section B.

For all three hour examination papers, ACCA has introduced 15 minutes reading and planning time.

This additional time is allowed at the beginning of each three-hour examination to allow candidates to read the questions and to begin planning their answers before they start writing in their answer books. This time should be used to ensure that all the information and exam requirements are properly read and understood.

During reading and planning time candidates may only annotate their question paper. They may not write anything in their answer booklets until told to do so by the invigilator.

The Essentials module papers all have a Section A containing a major case study question with all requirements totalling 50 marks relating to this case. Section B gives students a choice of two from three 25 mark questions.

Section A of each of the Options papers contains 50-70 compulsory marks from two questions, each attracting between 25 and 40 marks. Section B will offer a choice of two from three questions totalling 30-50 marks, with each question attracting between 15 and 25 marks.

The pass mark for all ACCA Qualification examination papers is 50%.

## GUIDE TO EXAMINATION ASSESSMENT

ACCA reserves the right to examine anything contained within the study guide at any examination session. This includes knowledge, techniques, principles, theories, and concepts as specified.

For the financial accounting, audit and assurance, law and tax papers except where indicated otherwise, ACCA will publish *examinable documents* once a year to indicate exactly what regulations and legislation could potentially be assessed within identified examination sessions..

For paper based examinations regulation **issued** or legislation **passed** on or before 30<sup>th</sup> September annually, will be assessed from June 1<sup>st</sup> of the following year to May 31<sup>st</sup> of the year after. Therefore, paper based examinations in June 2009, December 2009 (and March 2010 where applicable) will be assessed on regulations issued and legislation passed on or before 30 September 2008.

Regulation issued or legislation passed in accordance with the above dates may be examinable even if the **effective** date is in the future.

The term issued or passed relates to when regulation or legislation has been formally approved.

The term effective relates to when regulation or legislation must be applied to an entity transactions and business practices.

The study guide offers more detailed guidance on the depth and level at which the examinable documents will be examined. The study guide should therefore be read in conjunction with the examinable documents list.

# Syllabus

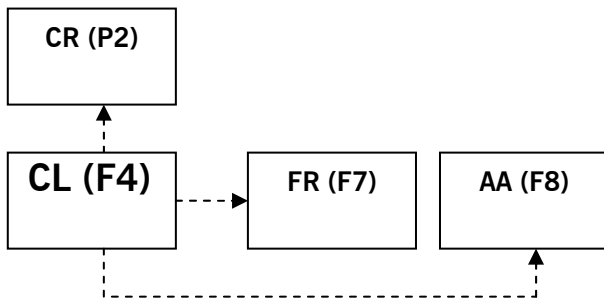

## AIM

To develop knowledge and skills in the understanding of the general legal framework, and of specific legal areas relating to business, recognising the need to seek further specialist legal advice where necessary

## MAIN CAPABILITIES

On successful completion of this paper candidates should be able to:

- A** Identify the essential elements of the legal system including the main sources of law
- B** Recognise and apply the appropriate legal rules relating to the law of obligations
- C** Distinguish between alternative forms and constitutions of business organisations
- D** Recognise and compare types of capital and the financing of companies
- E** Describe and explain how companies are managed, administered and regulated
- F** Recognise and apply the appropriate legal rules relating to majority control and minority protection
- G** Recognise the legal implications relating to companies in difficulty or in crisis
- H** Demonstrate an understanding of corporate governance and ethical issues relating to business

## RELATIONAL DIAGRAM OF MAIN CAPABILITIES

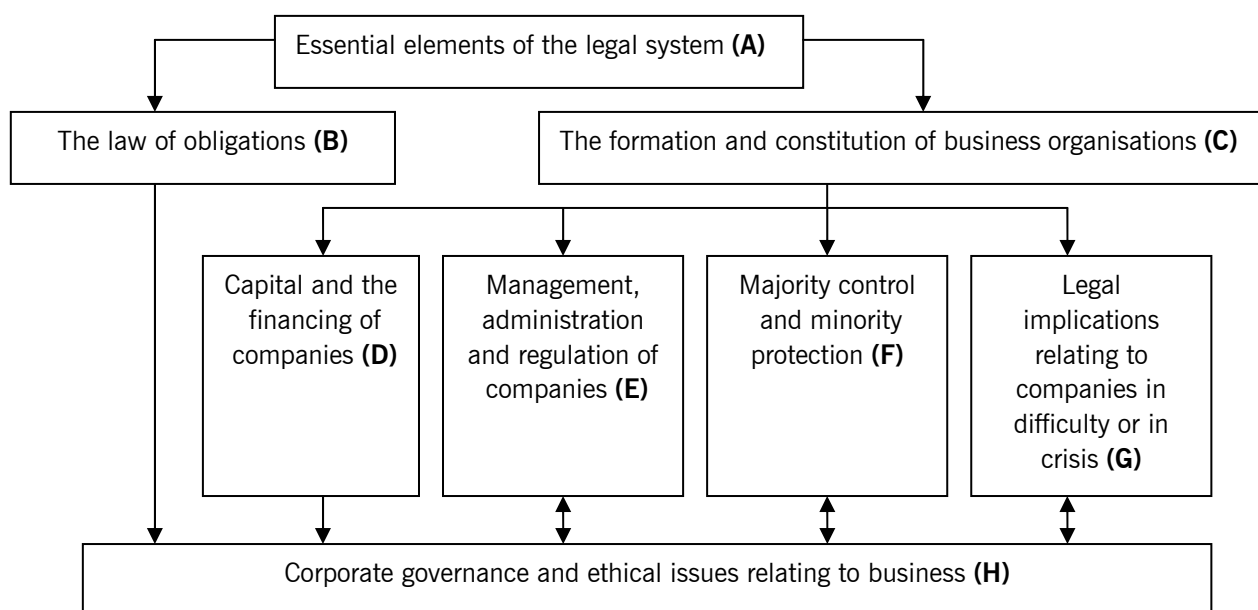

## **RATIONALE**

*Corporate and Business Law* is essentially divided into eight areas. The syllabus starts with an introduction to the overall legal system of Singapore, such as the court system and sources of law. It then leads into the area of the law of obligations including contracts and tort, which underpin business transactions generally.

The syllabus then covers a range of specific legal areas relating to various aspects of business of most concern to finance professionals. These are the law relating to business organisations and companies. These laws include the formation and constitution of companies, the financing of companies and types of capital, and the day to day management, the administration and regulation of companies, majority control and minority protection, and legal aspects of companies facing difficulty or in crisis.

The final section links back to all the previous areas. This section deals with corporate governance, ethics and ethical behaviour relating to business including criminal law.

## **DETAILED SYLLABUS**

### **A Essential elements of the legal system**

1. Court structure
2. Sources of law
3. Precedent and statutory interpretation
4. Reception of English Law in Singapore

### **B The law of obligations**

1. Formation of contract
2. Content of contracts
3. Vitiating factors
4. Discharge of contract, breach of contract and remedies
5. The law of torts
6. Professional negligence

### **C The formation and constitution of business organisations**

1. Types of business organisations
2. Partnerships and limited liability partnerships
3. Corporations and legal personality
4. Company formations

### **D Capital and the financing of companies**

1. Share capital
2. Loan capital
3. Capital maintenance and dividend law

### **E Management, administration and regulation of companies**

1. Company directors
2. Other company officers
3. Company meetings and resolutions

### **F Majority control and minority protection**

1. Majority rule and minority rights

### **G Legal implications relating to companies in difficulty or in crisis**

1. Insolvency

### **H Corporate governance and ethical issues relating to business**

1. Corporate governance
2. Fraudulent behaviour

## **APPROACH TO EXAMINING THE SYLLABUS**

The syllabus is assessed by a three hour paper-based examination.

The examination consists of seven 10 mark questions assessing knowledge of the law, and three 10 mark application questions.

## **NOTE ON CASE LAW**

Candidates should support their answers with analysis referring to cases or examples. There is no need to detail the facts of the case. Remember, it is the point of law that the case establishes that is important, although knowing the facts of cases can be helpful as sometimes questions include scenarios based on well-known cases.

# Study Guide

## **A ESSENTIAL ELEMENTS OF THE LEGAL SYSTEM**

### **1. Court structure**

- a) Explain the structure and operation of the courts and tribunals systems.<sup>[1]</sup>

### **2. Sources of law**

- a) Define law and distinguish types of law.<sup>[1]</sup>

### **3. Precedent and statutory interpretation**

- a) Explain what is meant by case law and precedent within the context of the hierarchy of the courts.<sup>[2]</sup>
- b) Illustrate the rules and presumptions used by the courts in interpreting statutes.<sup>[1]</sup>

### **4. Reception of English law in Singapore**

- a) Explain and evaluate how English law has been received in Singapore.<sup>[1]</sup>

## **B THE LAW OF OBLIGATIONS**

### **1. Formation of contract**

- a) Analyse the nature of a simple contract.<sup>[2]</sup>
- b) Explain the meaning of offer and distinguish it from invitations to treat.<sup>[2]</sup>
- c) Explain the meaning and consequence of acceptance.<sup>[2]</sup>
- d) Explain the meaning of and the need for consideration.<sup>[2]</sup>
- e) Analyse the doctrine of privity.<sup>[2]</sup>
- f) Distinguish the presumptions relating to intention to create legal relations.<sup>[2]</sup>

### **2. Content of contracts**

- a) Distinguish terms from mere representations.<sup>[2]</sup>

- b) Define the various contractual terms and their legal effect.<sup>[2]</sup>

- c) Explain the effect of exclusion clauses and evaluate their control under the Unfair Contract Terms Act.<sup>[2]</sup>

### **3. Vitiating factors**

- a) Explain what is meant by misrepresentation.<sup>[2]</sup>
- b) Distinguish between the types of misrepresentation and their legal effect.<sup>[2]</sup>
- c) Explain the effect of illegality on a contract.<sup>[1]</sup>

### **4. Discharge of contract, breach of contract and remedies**

- a) Explain the meaning and effect of discharge of contract by performance and frustration.<sup>[2]</sup>
- b) Explain the meaning and effect of breach of contract.<sup>[2]</sup>
- c) Explain the rules relating to the award of damages.<sup>[2]</sup>
- d) Analyse the remedies for breach of contract.<sup>[2]</sup>

### **5. The law of torts**

- a) Explain the meaning of tort.<sup>[2]</sup>
- b) Identify examples of torts including 'passing off' and negligence.<sup>[2]</sup>
- c) Explain the duty of care and its breach.<sup>[2]</sup>
- d) Explain the meaning of causality and remoteness of damage.<sup>[2]</sup>
- e) Discuss defences to actions in negligence.<sup>[2]</sup>

### **6. Professional negligence**

- a) Explain and analyse the duty of care of accountants and auditors.<sup>[2]</sup>

## **C THE FORMATION AND CONSTITUTION OF BUSINESS ORGANISATIONS**

### **1. Types of business organisations**

- a) Explain and distinguish the different types of business organisations including sole traders, partnerships, limited liability partnerships and companies.<sup>[1]</sup>

### **2. Partnerships and limited liability partnerships**

- a) Demonstrate a knowledge of the legislation governing the partnership, and the limited liability partnership.<sup>[1]</sup>
- b) Discuss how partnerships are established.<sup>[2]</sup>
- c) Explain the authority of partners in relation to partnership activity.<sup>[2]</sup>
- d) Analyse the liability of various partners for partnership debts.<sup>[2]</sup>
- e) Explain the way in which partnerships can be brought to an end.<sup>[2]</sup>

### **3. Corporations and legal personality**

- a) Explain the meaning and effect of limited liability.<sup>[2]</sup>
- b) Analyse different types of companies, especially private and public companies.<sup>[2]</sup>
- c) Illustrate the effect of separate personality.<sup>[2]</sup>
- d) Recognise instances where separate personality will be ignored.<sup>[2]</sup>
- e) Explain the doctrine of ultra vires and its effect.<sup>[2]</sup>

### **4. Company formations**

- a) Explain the role and duties of company promoters.<sup>[2]</sup>
- b) Describe the procedure for registering companies, both public and private.<sup>[2]</sup>
- c) Describe the statutory books, records and returns that companies must keep or make.<sup>[1]</sup>

- d) Explain the content and effect of the memorandum of association.<sup>[2]</sup>

- e) Describe the contents of Table A articles of association.<sup>[1]</sup>

- f) Analyse the effect of a company's constitutional documents.<sup>[2]</sup>

- g) Explain how articles of association can be changed.<sup>[2]</sup>

## **D CAPITAL AND THE FINANCING OF COMPANIES**

### **1. Share capital**

- a) Examine the different meanings of capital.<sup>[2]</sup>
- b) Illustrate the difference between various classes of shares.<sup>[2]</sup>
- c) Explain the procedure for altering class rights.<sup>[2]</sup>

### **2. Loan capital**

- a) Define companies' borrowing powers.<sup>[1]</sup>
- b) Explain the meaning and types of debenture.<sup>[2]</sup>
- c) Distinguish loan capital from share capital.<sup>[2]</sup>
- d) Explain the concept of a company charge and distinguish between fixed and floating charges.<sup>[2]</sup>
- e) Describe the need and the procedure for registering company charges.<sup>[2]</sup>

### **3. Capital maintenance and dividend law**

- a) Explain the doctrine of capital maintenance and capital reduction.<sup>[2]</sup>
- b) Explain the rules governing the distribution of dividends in both private and public companies.<sup>[2]</sup>

## **E MANAGEMENT, ADMINISTRATION AND REGULATION OF COMPANIES**

### **1. Company directors**

- a) Explain the role of directors in the operation of a company.<sup>[2]</sup>
- b) Explain the authority of directors.<sup>[2]</sup>
- c) Discuss the ways in which directors are appointed, can lose their office or be subject to a disqualification order.<sup>[2]</sup>
- d) Distinguish between the powers of the board of directors, the managing director and individual directors to bind their company.<sup>[2]</sup>
- e) Explain the duties that directors owe to their companies.<sup>[2]</sup>
- f) Explain the effect of a breach of directors' duties and the remedies available.<sup>[2]</sup>

### **2. Other company officers**

- a) Discuss the appointment procedure relating to, and the duties and powers of, a company secretary.<sup>[2]</sup>
- b) Discuss the appointment procedure relating to, and the duties and powers of, company auditors and audit committees.<sup>[2]</sup>

### **3. Company meetings and resolutions**

- a) Distinguish between types of meetings: ordinary and extraordinary general meetings and class meetings.<sup>[1]</sup>
- b) Explain the procedure for calling such meetings.<sup>[2]</sup>
- c) Detail the procedure for conducting company meetings.<sup>[1]</sup>
- d) Distinguish between types of resolutions: ordinary, extra-ordinary, special, elective and written.<sup>[2]</sup>

## **F MAJORITY CONTROL AND MINORITY PROTECTION**

### **1. Majority control and minority rights**

- a) Explain the division of power between directors and the general meeting.<sup>[2]</sup>
- b) Explain the doctrine of majority control and the remedies available.<sup>[2]</sup>
- c) Explain the doctrine of minority protection and the remedies available.<sup>[2]</sup>

## **G LEGAL IMPLICATIONS RELATING TO COMPANIES IN DIFFICULTY OR IN CRISIS**

### **1. Insolvency**

- a) Explain the meaning of and procedure involved in voluntary liquidation.<sup>[2]</sup>
- b) Explain the meaning of and procedure involved in compulsory liquidation.<sup>[2]</sup>
- c) Explain the protection of investors and creditors in a liquidation.<sup>[2]</sup>
- d) Explain the priority of payment in a liquidation.<sup>[2]</sup>
- e) Explain judicial management and other alternatives to winding up.<sup>[2]</sup>

## **H GOVERNANCE AND ETHICAL ISSUES RELATING TO BUSINESS**

### **1. Corporate governance**

- a) Explain the idea of corporate governance.<sup>[2]</sup>
- b) Recognise the extra-legal codes of corporate governance.<sup>[2]</sup>
- c) Identify and explain the legal regulation of corporate governance.<sup>[2]</sup>

### **2. Fraudulent behaviour**

- a) Recognise the nature and legal control over insider dealing.<sup>[2]</sup>

- b) Discuss potential criminal activity in the operation, management and winding up of companies.<sup>[2]</sup>
- c) Distinguish between fraudulent and wrongful trading.<sup>[2]</sup>

### **READING LIST**

B Tabalujan, V Du Toit-Low Singapore Business Law Business Law Asia

A Phang (ed) Basic Principles of Singapore Business Law Thomson

V Yeo, J Lee, P Hanrahan, I Ramsay, G Stapledon Commercial Applications of Company Law in Singapore CCH

P Koh, V Yeo Company Law Butterworths Asia

Low and Tabalujan Executive's Guide to Business and the Law Prentice Hall

R Card, J James Law for Accountancy Students Butterworths

K Lum, V Yeo Contract Law Butterworths Asia

W Woon Company Law Longman

R Chandran Introduction to Business Law in Singapore McGraw-Hill Education (Asia)

L H Tan, Ch Tan, H C Long Corporate Governance Of Listed Companies, Thomson Sweet & Maxwell Asia